

DRG. No. W31GE004/0

DRG. REF.

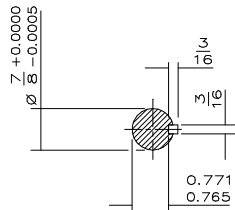
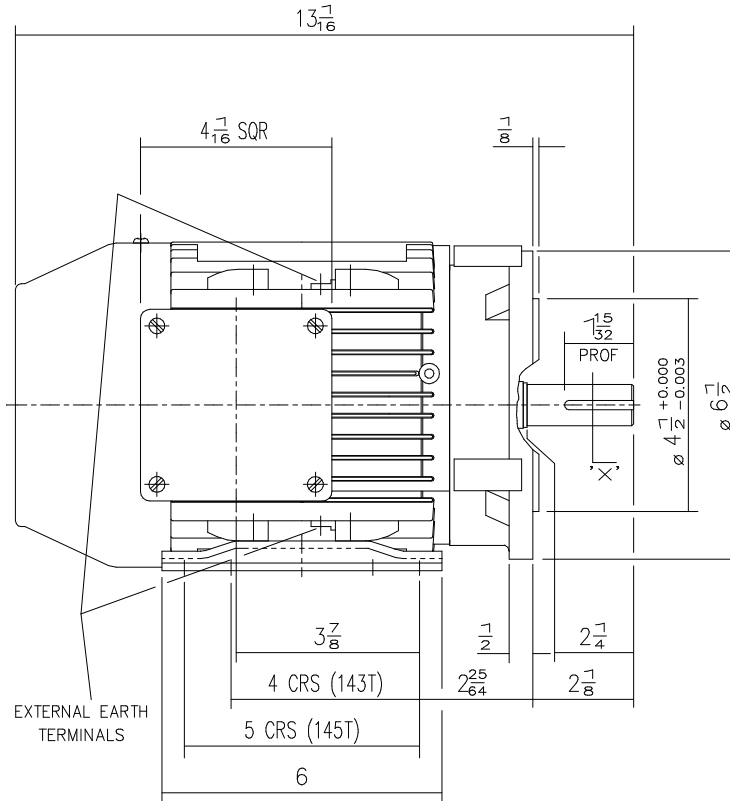
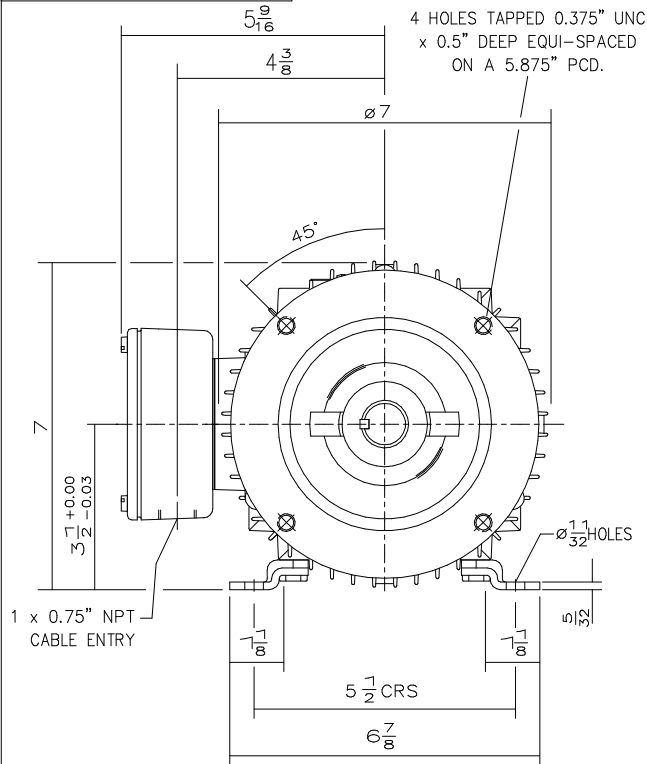

TERMINAL BOX CAN BE ARRANGED IN 3 OR 12 O'CLOCK POSITIONS.
CONDUIT ENTRIES: - TERMINAL BOX CAN BE ROTATED AT 90° INTERVALS
(CONDUIT ENTRY POSITION SHOWN FOR ILLUSTRATION ONLY)

CUSTOMER		
ORDER No.		
PART No.		
OUR ORDER No.		
FRAME SIZE		
KW.	RPM.	
Hz	PHASE	
VOLTS	POLES	
BRGS.	DE.	NDE.
MOTOR NETT WT.	Kg.	
SPECIAL REMARKS		

(ALL DIMENSIONS IN INCHES)



**BROOK
CROMPTON**

Huddersfield, HD1 3LJ
ENGLAND

SHEET TITLE
SIZE OUTLINE DIMENSION DRAWING W ALUMINIUM TOTALLY ENCLOSED FAN COOLED
A3 143/5 FRAME FACE WITH FEET MOUNTED MOTOR

	NAME	DATE
DRAWN	RR	24-07-01
CHECKED	DH	24-07-01
SCALE	1:2.5	

DRG. No.	W31GE004/0	
DRG. REF.		
REVISION:		DATE